



dual surface, clamp on lectern

MODEL #: 00470

DUAL SURFACE LECTERN, WITH CLAMP-ON ATTACHMENT

DIMENSIONS & FREIGHT

MODEL #	D"	W"	H"	F.C.	WEIGHT
00470	19"	19"	6"	70	22 lbs.

OVERVIEW

The Dual Surface Model #00470, can be attached to any of our tops using the easy clamp on system. The Lectern is easily adjusted in height and is fully versatile in its range of motion - a full 360° of motion with the fully actuating arm. The Dual Surface's of the lectern allow for easy access to any (2) items at once, i.e. a laptop computer on the lower shelf and a notebook on the upper shelf (as pictured) or any number of other combinations. The Dual Surface lectern has 16-gauge steel construction along with a reinforcement brace. Another key feature is the integrated pencil retainer.

COMPATIBILITY

Compatible with booktruck & cascade riser shelf tops and a wide variety of Smith System desks and tables.

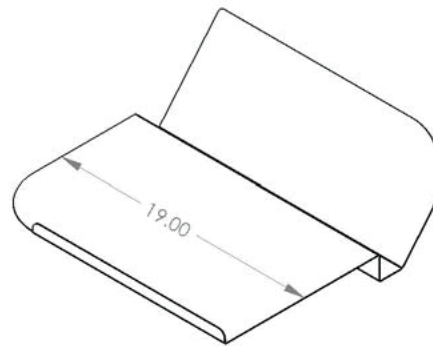
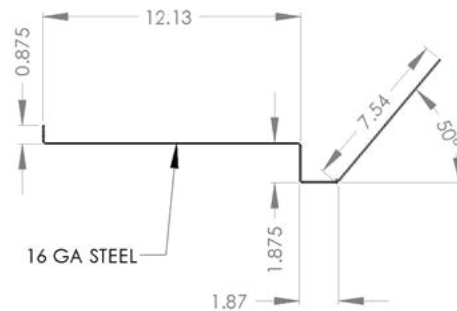
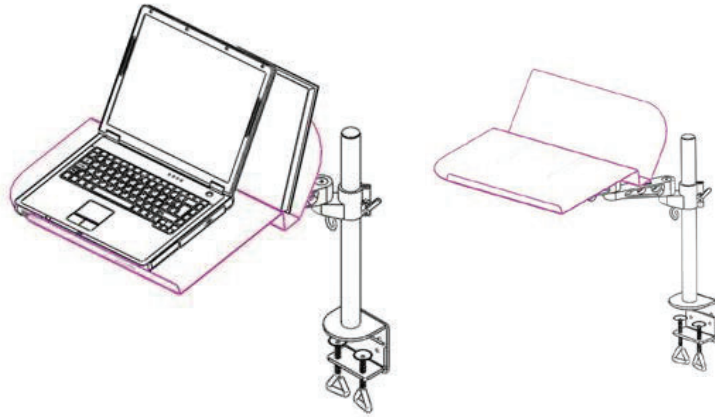



MODEL 00470 POLE COLOR



PLATINUM
PLT

MODEL 00470 COLOR OPTIONS



APPLE **A**



BLACK **B**



BLUEBERRY **C**



BURGUNDY **D**



CERULEAN **S**



CHARCOAL **R**



CHOCOLATE **Q**



CLEMENTINE **E**



FOREST GREEN **F**



FUCHSIA **G**



MINT **H**



MOCHA **T**



NAVY **I**



ORANGE **U**



PERSIAN BLUE **J**



PLATINUM **P**



PURPLE **K**



RED **L**



YELLOW **N**