



flat panel mount w/ swivel arm

MODEL #: 17352



OVERVIEW

This flat panel monitor mounts secure to your desk without occupying usable desk space needed for keyboards or other documents. The swivel arm is for maximum rotation and maximum extension of the monitor. The swivel arm prevents the monitor from blocking the view of the instructor. The swivel arm feature is suitable for all classrooms and computer lab environments including one-on-one tutorials.

The dimensions of the monitor mount measure approximately 18.05" in height, 4.5" in width. The arm has several degrees of freedom and extends up to 17.58 inches. The construction is 12 gauge cold-rolled steel with a mounting plate that is 11-gauge with standard hole patterns, VESA compliant. The mount is intended for 15", 17" and 19" flat panel monitors. This item can be mounted anywhere on the desk as long as there is enough clearance under the table for the 3.66" diameter washer.

DIMENSIONS

MODEL #	D"	W"	H"	WEIGHT
17352	21.15"	4.5"	18.05"	9 lbs.
carton	5"	5.5"	21"	

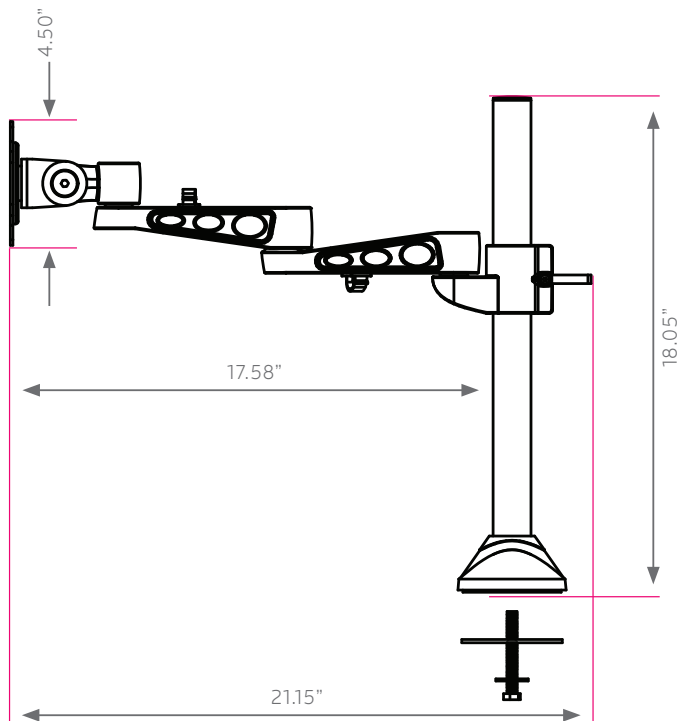

FRAME COLORS



PLATINUM
PLT

