



gorilla booktruck

18" x 36" - six sloping shelves

MODEL #: 21101

GORILLA BOOKTRUCK, 6 SLOPING SHELVES

DIMENSIONS & FREIGHT

MODEL #	D"	W"	H"	F.C.	WEIGHT
21101	18"	36"	44"	150	89 lbs.
carton	19"	37.5"	40"		

OVERVIEW

Smith System™ Book Trucks are a handy companion to the library or classroom, carrying up to 600 lb of books, paper and projects. Fixed middle casters make it easy for the truck to pivot on an axis which makes it great for getting over thresholds. Comes standard with dual wheel casters, 5", that won't shimmy like single wheel casters.

MATERIALS

Smith System™ Book Truck #21101 consists of (2) Frames, (2) End Panels, and (6) Sloping Shelf Weldments. The End Panels consist of 20-gauge steel plate welded to 1" square 18-gauge steel tubing Frame with formed in handles that radius for added comfort and ease of movement. The Shelves are constructed of 20-gauge steel that is 34" long x 17 9/16" deep x 1" high edge. The shelves sport a 12 3/4" clearance between shelves and are welded to the frames and end panels of the Book Truck. Gorilla Book Trucks feature 5" diameter dual wheel casters with soft tread, which also includes a six-wheel construction for easy maneuverability. Dual wheels have no saddle that may damage surrounding furniture.

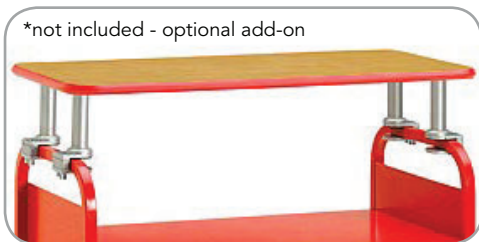

MODEL #	D"	W"	H"	F.C.	WEIGHT
21109	18"	38"	1.25"	70	19 lbs.

OPTIONAL BOOKTRUCK TOP #21109

Add this optional Booktruck Riser Shelf with 1 1/4" thick laminated top with either our 3/8" bumper or 4mm edge banding. The Riser-Poles clamp onto the booktruck handles and come in a Platinum finish. The shelf stands 6" above the booktruck handles.

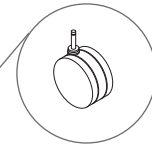

5" DIA. CASTERS

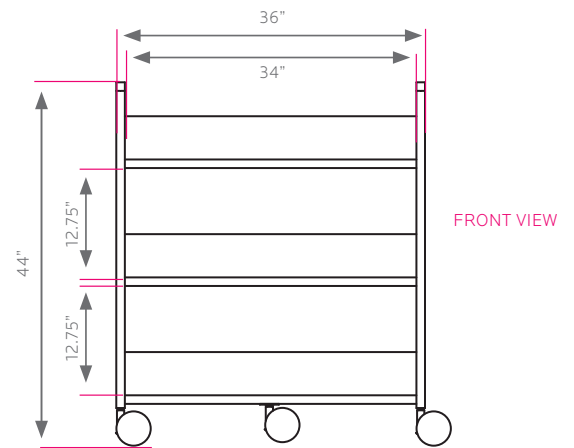
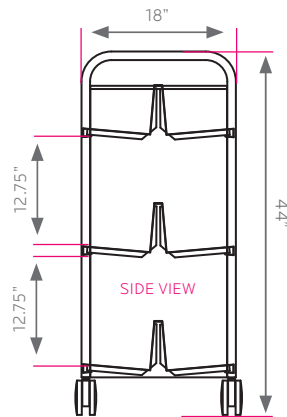
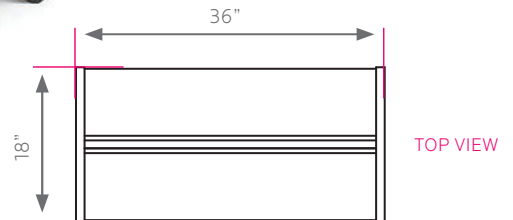

QS (QUICK-SHIP) BOOKTRUCK COLORS

Quickship colors up to 5. If more than 5, 8 week lead



BLACK



PERSIAN BLUE



PLATINUM



RED



SAND

EXTENDED LEADTIME BOOKTRUCK COLORS

8-Week lead-time colors.



APPLE



CERULEAN



CLEMENTINE



FOREST GREEN



NAVY



PURPLE