



cascade spiral noteboard *with shelves*

MODEL #: 211T0000P_

MID-CASE SPIRAL NOTEBOARD W/ SHELVES

OVERVIEW

The Cascade series provides storage for a wide variety of items. The Mid-Case Spiral Noteboard is a medium width cabinet in the Cascade grouping, measuring in at 70.75" tall, 28.75" wide and 19" deep.

MATERIALS

The END PANELS are made of 18-gauge 1" square tubing, welded flush to an 18-gauge end panel. The inside of each end panel is reinforced by 22-gauge hat channels. These hat channels are dual purpose: added strength and for tote rail shelf mounting. The dome top is 18-gauge formed and welded construction, bolted to each end panel and rear panel with a total of 10 machine screw fasteners. The base is a durable 18-gauge steel construction formed and welded to support the entire weight of the unit squarely. Underneath is a heavy welded hat channel reinforcement. The base shelf is attached to both end panels using 4 machine screw fasteners. The Rear Panel is 18-gauge steel reinforced with up to three vertical hat channels. Two grommet holes (a lower and upper) are punched for convenient wire management and electronic storage. Casters are 4" in diameter, with 2 locking. Optional glides are 3/8" threaded stem.

The SPIRAL NOTEBOARD comes fully assembled. The noteboard's write on surface is constructed of 16-gauge steel with a white dry erase powder paint finish. The shelf inside the noteboard is a Platinum finish, with the spiral topper being a Chrome finish.

The optional DOORS include a secure and reliable locking mechanism, which engages lock rods into the dome top and the base shelf. Doors also come with urethane ergonomic and modern door handles of your color choice. The fully hinged doors articulate 270 degrees, free of obstruction.

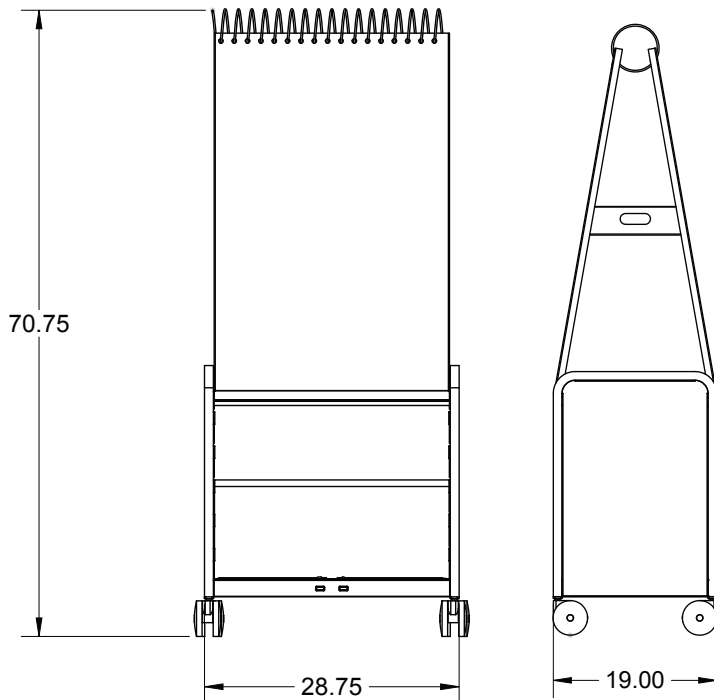

MID-CASE W/ SHELVES

MODEL	DESCRIPTION	D"	W"	H"	F.C.	WT.
<i>Shelves</i>						
211T0000P_	Open w/shelves	19	29	70.75	100	78
221T0000P_	Doors w/shelves	19	29	70.75	100	89
	pallet dimensions	26	34	32		



cascade spiral noteboard with totes

MODEL #: 210T1000P_

MID-CASE SPIRAL NOTEBOARD W/ TOTES

OVERVIEW

The Cascade series provides storage for a wide variety of items. The Mid-Case Spiral Noteboard is a medium width cabinet in the Cascade grouping, measuring in at 70.75" tall, 28.75" wide and 19" deep.

MATERIALS

The END PANELS are made of 18-gauge 1" square tubing, welded flush to an 18-gauge end panel. The inside of each end panel is reinforced by 22-gauge hat channels. These hat channels are dual purpose: added strength and for tote rail shelf mounting. The dome top is 18-gauge formed and welded construction, bolted to each end panel and rear panel with a total of 10 machine screw fasteners. The base is a durable 18-gauge steel construction formed and welded to support the entire weight of the unit squarely. Underneath is a heavy welded hat channel reinforcement. The base shelf is attached to both end panels using 4 machine screw fasteners. The Rear Panel is 18-gauge steel reinforced with up to three vertical hat channels. Two grommet holes (a lower and upper) are punched for convenient wire management and electronic storage. Casters are 4" in diameter, with 2 locking. Optional glides are 3/8" threaded stem.

The SPIRAL NOTEBOARD comes fully assembled. The noteboard's write on surface is constructed of 16-gauge steel with a white dry erase powder paint finish. The shelf inside the noteboard is a Platinum finish, with the spiral topper being a Chrome finish.

The optional DOORS include a secure and reliable locking mechanism, which engages lock rods into the dome top and the base shelf. Doors also come with urethane ergonomic and modern door handles of your color choice. The fully hinged doors articulate 270 degrees, free of obstruction.

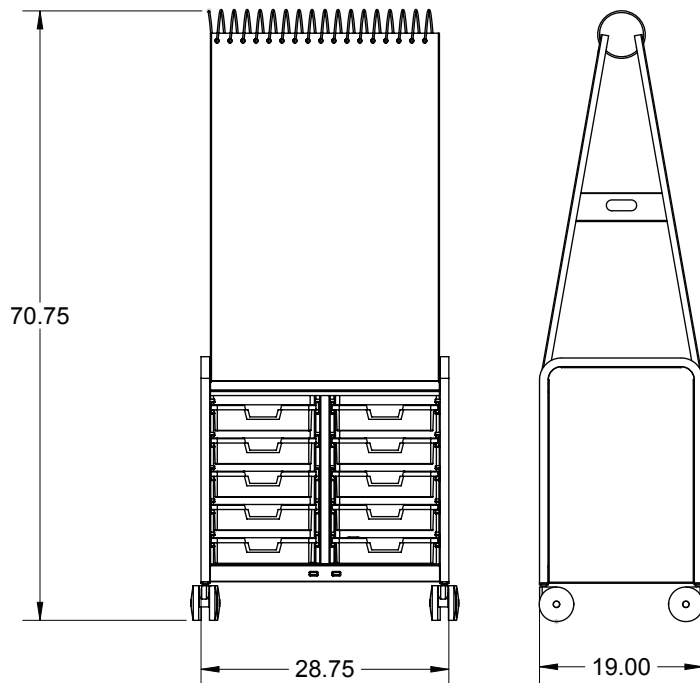

MID-CASE W/ TOTES

MODEL	DESCRIPTION	D"	W"	H"	F.C.	WT.
<i>Standard Width (SW) Totes</i>						
210T1000P_	Open w/ten 3" SW totes	19	29	70.75	100	84
220T1000P_	Doors w/ten 3" SW totes	19	29	70.75	100	95
210T06020P_	Open w/six 3" & two 6" SW totes	19	29	70.75	100	85
220T06020P_	Doors w/six 3" & two 6" SW totes	19	29	70.75	100	96
	pallet dimensions	26	34	32		

CASCADE FRAME



PLATINUM

CASCADE END PANEL AND EDGE COLOR OPTIONS



APPLE **A**



BLACK **B**



BLUEBERRY **C**



BURGUNDY **D**



CERULEAN **S**



CHARCOAL **R**



CHOCOLATE **Q**



CLEMENTINE **E**



FOREST GREEN **F**



FUCHSIA **G**



MINT **H**



MOCHA **T**



NAVY **I**



ORANGE **U**



PERSIAN BLUE **J**



PLATINUM **P**



PURPLE **K**



RED **L**



YELLOW **N**

