



in2it™ adjustable stool

22" - 32" adjustable seat height, A shell

MODEL #: 00546, 00547

IN2IT ADJUSTABLE STOOL (A SHELL)

DIMENSIONS + FREIGHT *product is UPSable.

MODEL #	D"	W"	H"	F.C.	CUBE	WEIGHT
00546 (glides)	28"	28"	22" - 32"	85	2.1	37 lbs.
00547 (casters)	28"	28"	22" - 32"	85	2.1	37 lbs.

OVERVIEW

The In2it is our most ergonomic option with unmatched comfort and style. This adjustable stool allows you to move around freely and help maintain support for your back, legs and arms as you change body positions. It's shape was purely derived as an invitation to come sit and learn. Meanwhile, it's ample dimensions makes students of all sizes comfortable throughout the day. The In2it chair is the latest expression of furniture that contributes to a healthy, effective learning environment.

MATERIALS

The SHELL is 100% virgin polypropylene material with color throughout and a distinct texture to prevent slipping. The free flowing design of the In2it comes from the innovative use of Gas Injection Technology. The integrated handle eases classroom positioning.

The shell is anchored securely to the FRAME with an 11-gauge plate mounted by 4 screws beneath the chair. The plate attaches to a pneumatic lift, which is a hydraulic cylinder that adjusts from 22" - 32" in height. The lift also allows a full 360 degrees of swivel. The BASE has a 28" diameter 5-star design for added stability. The base comes in black nylon, featuring a foot ring and a choice of glides or 2" soft tread casters.

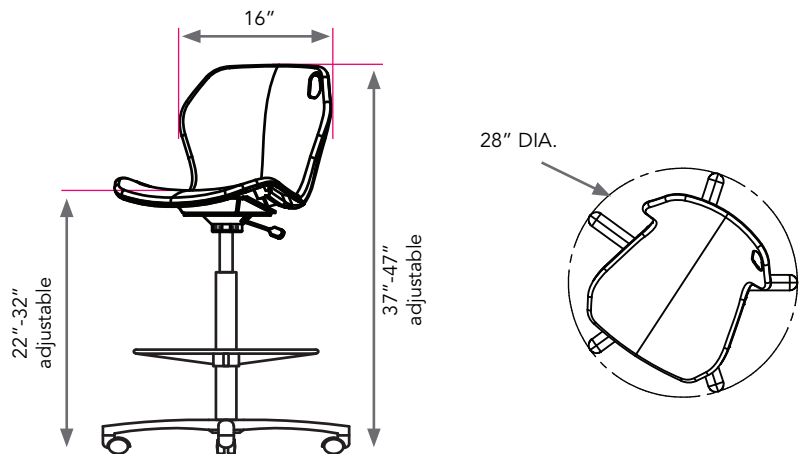

5-Star Base Color Options



BLACK
BLA

In2it™ Shell Color Options



APPLE A



BLACK B



BLUEBERRY C



BURGUNDY D



CERULEAN S



CHARCOAL R



CHOCOLATE Q



CLEMENTINE E



FOREST GREEN F



FUCHSIA G



MINT H



MOCHA T



NAVY I



PERSIAN BLUE J



PURPLE K



RED L



YELLOW N



Model 00532 (glides)
Model 00533 (casters)
B Shell Adjustable



Model 00536 (glides)
Model 00537 (casters)
A Shell Adjustable



Model 00546 (glides)
Model 00547 (casters)
A Shell Adjustable