



# Cascade<sup>®</sup> Air

## mid-cabinet

MODEL #: Z20000000HPP



### OVERVIEW

The Cascade Air provides storage and portable HEPA air purifiers to reduce in-air aerosols. Its HEPA filter captures 99.97 percent of airborne particles. The Mid-Cabinet is a medium width, medium height cabinet in the Cascade grouping, measuring in at 43 5/16" tall, 28 5/8" wide and 19" deep.

### MATERIALS

The END PANELS are made of 18-gauge 1" square tubing, welded flush to an 18-gauge end panel. The inside of each end panel is reinforced by 22-gauge hat channels. These hat channels are dual purpose: added strength and for tote rail shelf mounting. The dome top is 18-gauge formed and welded construction, bolted to each end panel and rear panel with a total of 10 machine screw fasteners. The base is a durable 18-gauge steel construction formed and welded to support the entire weight of the unit squarely. Underneath is a heavy welded hat channel reinforcement. The base shelf is attached to both end panels using 4 machine screw fasteners. The base is a durable 18-gauge steel construction formed and welded to support the entire weight of the unit squarely. Casters are 4" in diameter, with 2 locking.

DOORS include a secure and reliable locking mechanism, which engages lock rods into the dome top and the base shelf. Doors also come with urethane ergonomic and modern door handles of your color choice. The fully hinged doors articulate 270 degrees, free of obstruction.



FILTER	HEPA certified
WEIGHT	145 lbs
DECIBELS	53.8 - 67.7 (dependant on unit variable speed)
VOLTAGE	115V

### FRAME COLOR:



### DIMENSIONS

Model	Description	D"	W"	H"	F.C.	Cube	WT
Z20000000HPP_	Cascade Air Mid Cabinet	20	31.1	43.3			145
	shipping dimensions	26	48	46.75	250	33.76	170

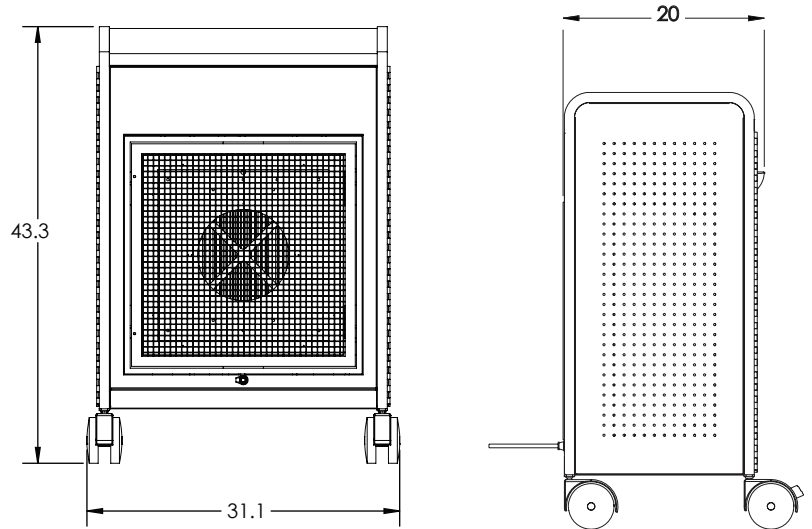

Cascade Air shown with open doors and HEPA filter.