



# Smith System®

Specification Sheet

WWW.SMITHSYSTEM.COM

## Flowform® Learn Lounge Flowform Learn Lounge 10" Double Seat

MODEL#: 55058



### OVERVIEW

Flowform Learn Lounge 10" Double Seat provides comfort to students due to the 103° angled seatback that offers support in a position appropriate for the desired work mode.

### MATERIALS

The structure is constructed of a 3/4" birch plywood frame which is made from Sustainable Forestry Initiative (SFI) certified responsible wood sources. The seating pad is made from high density foam meeting CAL 117 standards and contains no added flame retardant chemicals. Comes with reversible nylon & felt glides.

The fabric is Designtex Alphabet 100% vinyl, with a 1,000,000 D.R. Durability rating. The backing of the fabric is polyester. The fabric is highly durable and is easily cleanable with a Water:Bleach mixture.

### VINYL COLOR OPTIONS:

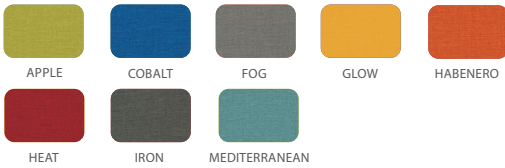

### VINYL COLOR OPTIONS WITH LEAD TIME:



### DIMENSIONS

Model	Description	D"	W"	H"	WT
55058	10" Double Seat	21.1	30.6	10	24.5

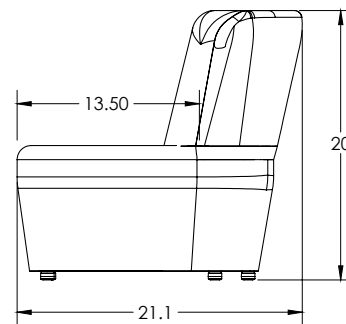
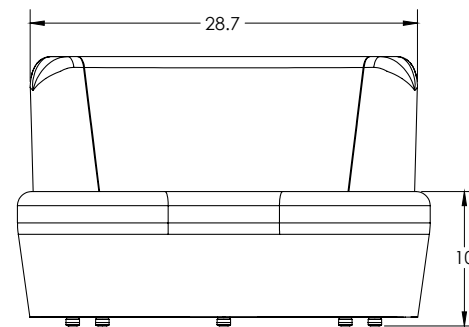
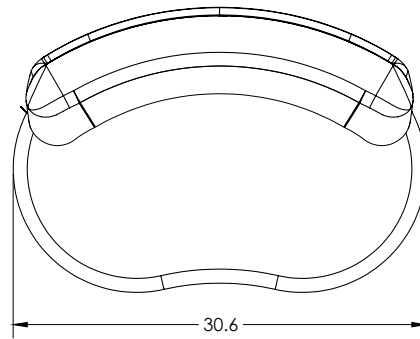

### DESIGNTEX

PATTERN	Alphabet
CONTENT	100% Vinyl
BACKING	Polyester, Knit
FLAME RESISTANCE	CA Bulletin 117-2013
DURABILITY	1,000,000 D. R.
MAINTENANCE	W: Bleach Cleanable (10:1)
FINISH	Advanced Protective Topcoat